

DBAR CUSHION BOX

REVOLUTIONIZING GRAIN FLOW EQUIPMENT

DBAR's patented design is setting the bar for grain flow equipment. DBAR features an internal cone with an adjustable baffle that collects and cushions grain while minimizing grain damage. LCDM developed DBAR to be a cost-effective solution to produce a consistent pocket of high-quality grain.

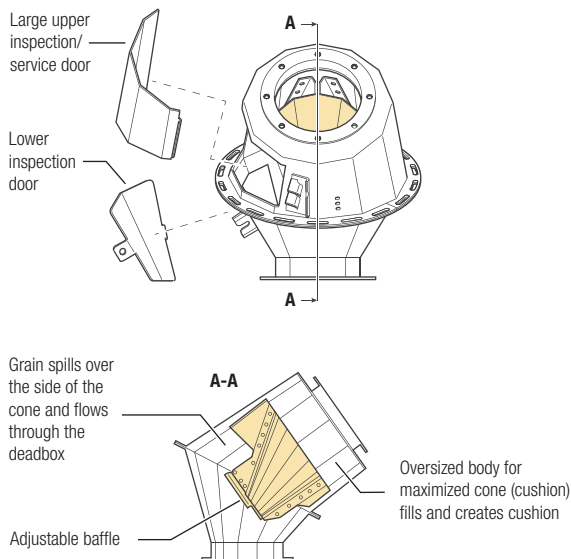

KEY FEATURES

- » ELIMINATES THE NEED FOR FLOW RETARDERS
- » PERFORMS IN BOTH FULL AND PARTIAL CAPACITY SITUATIONS
- » ADJUSTABLE BAFFLE TO CUSTOMIZE THE LEVEL OF CUSHION
- » REPLACEABLE INTERNAL PARTS
- » ADJUSTABLE BAFFLE FOR SELF CLEANING FLOW EQUIPMENT.
- » AVAILABLE IN PAINTED, GALVANIZED AND STAINLESS STEEL



SCAN THE QR CODE TO LEARN
MORE OR CONTACT US.

LCDMcorp.com



WHERE THE FUTURE OF
GRAIN HANDLING IS BUILT.

DBAR CUSHION BOX

At LCDM, we've recognized and filled the need for improved design and engineering of grain flow products. Our advanced adjustable cushion box is the culmination of four decades of material handling equipment expertise that has made us an undisputed industry leader.

The **DBAR** is ideally suited for grain-on-grain cushion box applications where the grain legs are not operating at full capacity, as well as for times when you need to vary the capacity of the spout between full and half-full. The self-cleaning inner cone also produces excellent results during operations where there's a high risk of cross-contamination.

The competitive difference - Versatility. DBAR can be adapted to meet your needs.

ADDITIONAL FEATURES



EASY SETUP WITH MINIMAL TIME AND LABOR REQUIRED FOR INSTALLATION



TWO CONVENIENTLY LOCATED OVERSIZED SERVICE DOORS



HEAVY-DUTY 8-GAUGE BODY WITH A HOT DIP GALVANIZED FINISH



WIDE VARIETY OF LINER OPTIONS (BLUE URETHANE, KRYPTANE, EXTREME GREEN)

PART NUMBER	A	B	C	D	E	F
DBAR0808GDx	8	9	19--1/8	6--3/4	14	16
DBAR1008GDx	10	11	22--3/4	9--1/8	17	20
DBAR1208GDx	12	13	26--3/4	11--1/8	20	24
DBAR1408GDx	14	15	30--7/8	12--7/8	23	28
DBAR1608GDx	16	17	34--7/8	14--5/8	26	32
DBAR1808GDx	18	19	39	16--3/8	28	40
DBAR2008GDx	20	21	43	18--1/8	32	44

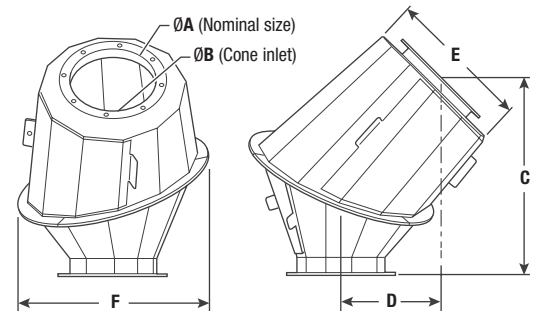

LEARN MORE ABOUT OUR OTHER SERVICES



CUSTOM GRAIN FLOW
PRODUCT DESIGN



GRAIN FLOW FACILITY
ENGINEERING



GRAIN FLOW
DISTRIBUTION

LOCATIONS

—
22394 US HWY 136
MEMPHIS, MO 63555

—
871 RANGE END RD,
DILLSBURG, PA 17019

CONTACT US TODAY

(888) 963-9145
contact@LCDM Corp.com

LCDM

ENGINEERED
GRAIN HANDLING
PRODUCTS